

Customer:		Ref.:	
Item	Quantity	Required flow rate	n.d.
Type	SUBMERSIBLE ELECTRIC PUMP FOR WASTE WATER	Model	DRL100T-230-400V
		Required head	n.d.

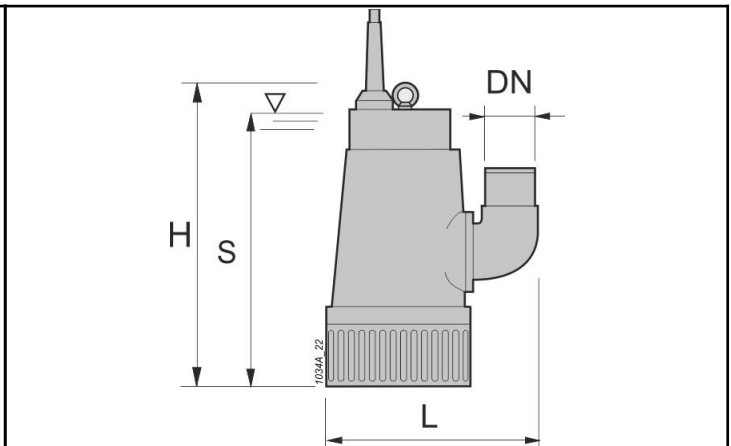
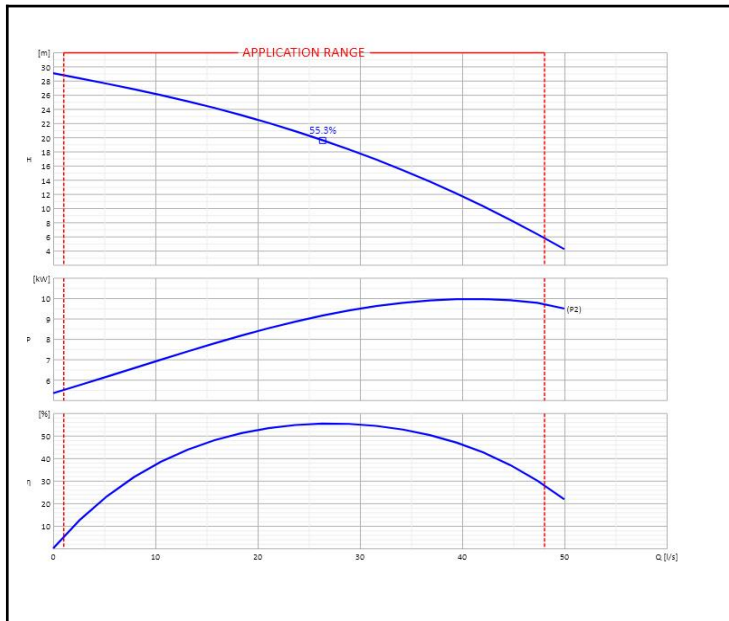

Dimensioni [mm]	
DNm	100 (*)
H	722
L	460
S	200

OPERATING DATA - ISO 9906:2012 3B -					CONSTRUCTION CHARACTERISTICS			
Q [l/s]	H [m]	P [kW]	η [%]	NPSH [m]	Delivery diameter		mm	
					Type of Impeller		Open impeller	
					Moment of inertia		n.d.	
					Electric pump weight	Installation	87	Kg
					Seal on pump side	Motor side	Mechanical	Mechanical
					Type of installation	n.d.		
					Operation	Continuous (S1)		

OPERATING LIMITS				OPERATING CHARACTERISTICS			
Pumped liquid	Waste water			Service flow rate	n.d.		n.d.
Max. temperature of pumped liquid	40	°C		Service head	n.d.		n.d.
Maximum density	1	kg/dm ³		H (Q=0)	Hmax	0	28.78
Maximum viscosity	1	mm ² /s		Qmin	Qmax	1	48
Max. solid content	n.d.	%		Power consumption at duty point	n.d.		n.d.
Max. number of starts/hr	15			Max power consumption	9.95		kW
Free passage	6	mm		Pump efficiency	Overall	n.d.	n.d.
Minimum immersion depth	n.d.	n.d.		Sense of rotation (*)	Clockwise		
				Number of pumps installed	Operating	Stand-by	
					1	0	

ELECTRIC PUMP MATERIALS		ELECTRIC MOTOR CHARACTERISTICS			
Round power cable	n.d.	Nominal power	10		kW
Stator	Electrical steel	Rated frequency	50		Hz
Motor casing	Aluminium	Rated voltage	400		V
Rotor	Electrical steel	Rated current	19		A
Mechanical seal	Ceramic/graphite	No. Poles	Rotation speed	2	2850
Strainer	Stainless steel				1/min
Impeller	Stainless steel	Type of motor	3 ~		
Mechanical seal on pump side	Silicon carbide/silicon carbide	Efficiency 4/4	83.3 %		
Delivery casing	Aluminium	Power factor 4/4			
Wear plate	Stainless steel/rubber	Is/In	Ts/Tn	n.d.	n.d.
Pump casing	Aluminium/rubber	Thermal protection			
		Insulation class	F		
		Protection class	IP68		
		Explosion-proof	n.a.		
		Power supply cable	Length	H07RN8	20
		Efficiency class	S.F		n.d.

Notes:	(*) Viewed from motor coupling side	
OFFER No.	Pos.	Date
		16/01/2020