

<b>Customer:</b>		<b>Ref.:</b>	
<b>Item</b>	Quantity	<b>Required flow</b>	n.d.
<b>Type</b>	CENTRIFUGAL PUMP WITH HORIZONTAL SHAFT	<b>Model</b>	PMXT65/2A

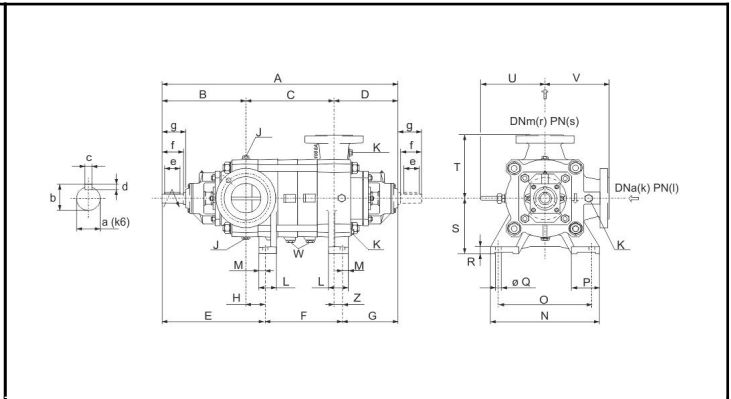
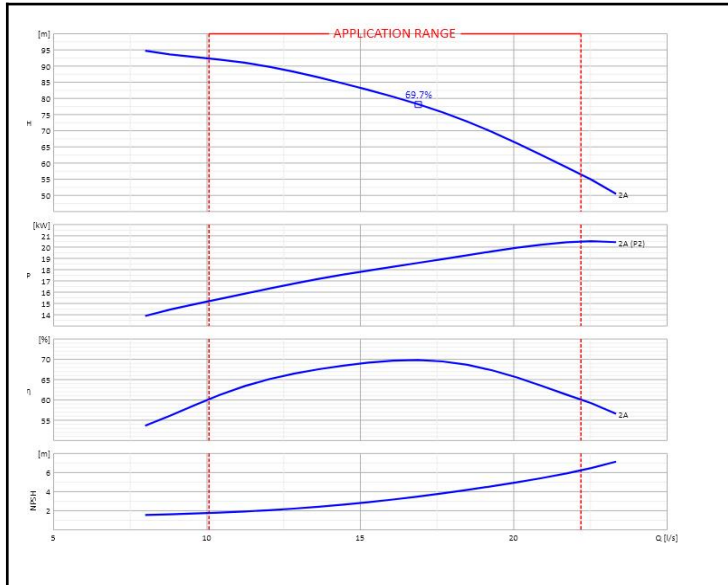

A	687.5	K	G 3/8	T	220	e	60
B	288.5	L	65	U	239	f	75
C	170	M	20	V	220	g	90
D	229	N	370	W	G 1/4	k	80
E	353.5	O	320	Z	30	l	25
F	135	P	90	a	32	r	65
G	199	Q	18	b	35	s	40
H	65	R	23	c	10		
J	G 1/2	S	180	d	8		

OPERATING DATA - ISO 9906:2012 3B -					CONSTRUCTION CHARACTERISTICS			
Q [l/s]	H [m]	P [kW]	η [%]	NPSH [m]	UNI delivery flange DN	65	PN	40
					UNI suction flange DN	80	PN	25
					Total weight	127		Kg
					No. Stages		2	
					Pump seal		Mechanical	
					Type of installation		Horizontal	

OPERATING LIMITS			OPERATING CHARACTERISTICS		
Pumped liquid	Water		Service flow rate	n.d.	n.d.
Max. temperature of pumped liquid	n.d.		Service head	n.d.	n.d.
Maximum density	1	kg/dm³	Qmin	10.07	22.19
Maximum viscosity	1	mm²/s	H (Q=0)	95.15	92.21
Max. solid content	0	g/m³	Hmax (Qmin)		
Max. no. starts/hr	n.d.		P2 Duty Point	n.d.	20.44
Maximum operating time with closed port	2min (3500 rpm) 6min (1450 rpm) [40 °C]		P2max		kW
			Pump hydraulic efficiency	n.d.	n.d.
			Rotation speed	2900	1/min
			Sense of rotation (*)	Clockwise	
			Number of pumps installed	Operating	Stand-by
				1	0

PUMP MATERIALS			
Delivery casing	Stainless steel		
Bearing support	Stainless steel		
Impeller	Stainless steel		
Suction casing	Stainless steel		
Pump shaft	Stainless steel		
Bearing flange	Stainless steel		
Diffuser	Stainless steel		
Casing	Stainless steel		
Impeller wear ring	Stainless steel		
Drum wear ring	Stainless steel		
Tie rod	Stainless steel		
Shaft sleeve	Stainless steel		
V seal ring	Rubber		
Bearing	Stainless steel		
OR seal ring	Rubber		

<b>Notes:</b>	(*) View from motor coupling side		
OFFER No.	Pos.	Date 17/01/2020	