

Customer:		Ref.:	
Item	Quantity	Required flow	n.d.
Type	CENTRIFUGAL PUMP WITH HORIZONTAL SHAFT	Model	NCH125-500

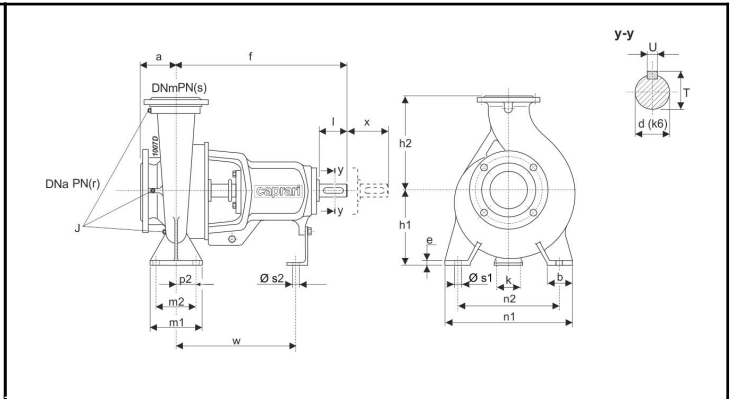
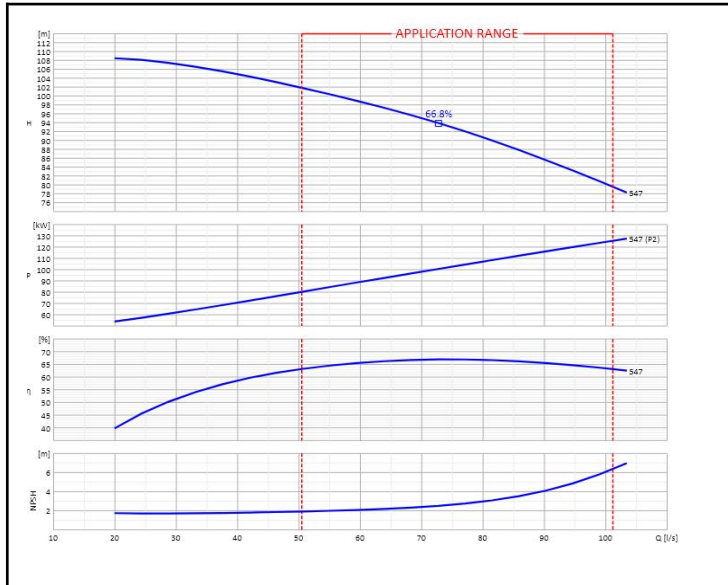

DNm	125	f	670	n2	450
DNa	150	k	140	p2	n.d.
J	G1/4x3	l	110	s2	18
T	51.5	r	16	h1	355
U	14	s	16	m1	200
a	160	w	500	n1	550
b	100	x	180	s1	23
d	48	h2	450		
e	25	m2	150		

OPERATING DATA - ISO 9906:2012 3B - M.E.I. ≥ 0.40					CONSTRUCTION CHARACTERISTICS				
Q [l/s]	H [m]	P [kW]	η [%]	NPSH [m]	UNI delivery flange DN		125	PN	16
					UNI suction flange DN		150	PN	16
					Total weight		359		Kg
					No. Stages		1		
					Pump seal		Mechanical		
					Type of installation		Horizontal		

OPERATING LIMITS			OPERATING CHARACTERISTICS			
Pumped liquid	Water		Service flow rate		n.d.	n.d.
Max. temperature of pumped liquid	n.d.		Service head		n.d.	n.d.
Maximum density	1	kg/dm³	Qmin	Qmax	50.47	101.15
Maximum viscosity	1	mm²/s	H (Q=0) Hmax (Qmin)		110.6	101.76
Max. solid content	50	g/m³	P2 Duty Point	P2max	n.d.	125.14
Max. no. starts/hr	n.d.		Pump hydraulic efficiency		n.d.	n.d.
Maximum operating time with closed port	2min (3500 rpm) 6min (1450 rpm) [40 °C]		Rotation speed		1450	1/min
			Sense of rotation (*)		Clockwise	
			Number of pumps installed		Operating	Stand-by
					1	0

PUMP MATERIALS	
Pump casing	Cast iron
Impeller	Cast iron
Lantern bracket	Cast iron
Shaft	Stainless steel
Wear ring	Cast iron
Support	Cast iron
Bearing	n.d.
Water retainer ring	Nitrile rubber
Feather key	Stainless steel
Feather key 2	Steel
Seal ring	Nitrile rubber
Mechanical seal	Silicon carbide/silicon carbide
Spacer sleeve	Stainless steel
Seal ring	Nitrile rubber
Cover mechanical seal	Cast iron
Duck foot pedestal	Steel
Cover bearing	Cast iron

Notes:	(*) View from motor coupling side	
OFFER No.	Pos.	Date 16/01/2020