

| | | | |
|------------------|--|----------------------|------------------|
| Customer: | | Ref.: | |
| Item | Quantity | Required flow | n.d. |
| Type | CENTRIFUGAL PUMP WITH HORIZONTAL SHAFT | Model | NC100-250 |

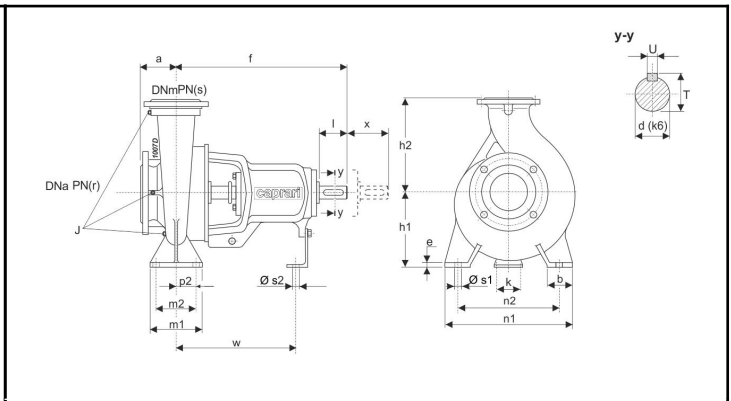
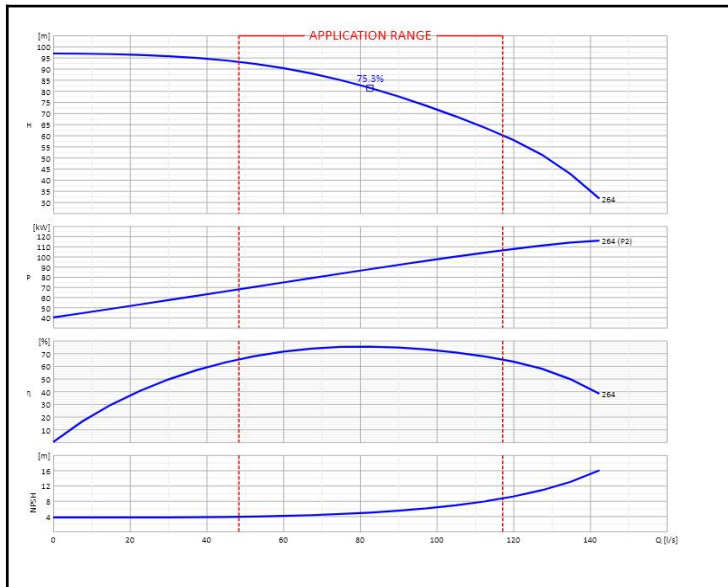

| | | | | | |
|-----|---------|----|-----|----|------|
| DNm | 100 | f | 470 | n2 | 315 |
| DNa | 125 | k | 110 | p2 | n.d. |
| J | G3/8x3, | l | 80 | s2 | 14 |
| T | 35 | r | 16 | h1 | 225 |
| U | 10 | s | 16 | m1 | 160 |
| a | 140 | w | 340 | n1 | 400 |
| b | 80 | x | 140 | s1 | 18 |
| d | 32 | h2 | 280 | | |
| e | 16 | m2 | 120 | | |

| OPERATING DATA - UNI/ISO 9906:2012 grade 3B - M.E.I.≥0.40 | | | | | CONSTRUCTION CHARACTERISTICS | | | |
|---|-------|--------|-------|----------|------------------------------|-----|------------|----|
| Q [l/s] | H [m] | P [kW] | η [%] | NPSH [m] | | | | |
| | | | | | UNI delivery flange DN | 100 | PN | 16 |
| | | | | | UNI suction flange DN | 125 | PN | 16 |
| | | | | | Total weight | 106 | | Kg |
| | | | | | No. Stages | | 1 | |
| | | | | | Pump seal | | Mechanical | |
| | | | | | Type of installation | | Horizontal | |

| OPERATING LIMITS | | | OPERATING CHARACTERISTICS | | | |
|---|---|--------|---------------------------|-------|-----------|----------|
| Pumped liquid | Water | | Service flow rate | | n.d. | n.d. |
| Max. temperature of pumped liquid | n.d. | | Service head | | n.d. | n.d. |
| Maximum density | 1 | kg/dm³ | Qmin | Qmax | 48.32 | 117.1 |
| Maximum viscosity | 1 | mm²/s | H (Q=0) Hmax (Qmin) | | 96.81 | 93.02 |
| Max. solid content | 50 | g/m³ | P2 Duty Point | P2max | n.d. | 106.02 |
| Max. no. starts/hr | n.d. | | Pump hydraulic efficiency | | n.d. | n.d. |
| Maximum operating time with closed port | 2min (3500 rpm) 6min (1450 rpm) [40 °C] | | Rotation speed | | 2900 | 1/min |
| | | | Sense of rotation (*) | | Clockwise | |
| | | | Number of pumps installed | | Operating | Stand-by |
| | | | | | 1 | 0 |

| PUMP MATERIALS | | | |
|-----------------------|---------------------------------|--------------------|-----------|
| Pump casing | Cast iron | Stuffing box | n.d. |
| Impeller | Cast iron | Duck foot pedestal | Steel |
| Lantern bracket | Cast iron | Cover bearing | Cast iron |
| Shaft | Stainless steel | | |
| Wear ring | Cast iron | | |
| Support | Cast iron | | |
| Bearing | n.d. | | |
| Water retainer ring | Nitrile rubber | | |
| Feather key | Stainless steel | | |
| Feather key 2 | Steel | | |
| Seal ring | Nitrile rubber | | |
| Mechanical seal | Silicon carbide/silicon carbide | | |
| Packing | n.d. | | |
| Spacer sleeve | Stainless steel | | |
| Shaft sleeve | n.d. | | |
| Seal ring | Nitrile rubber | | |
| Cover mechanical seal | Cast iron | | |

| | | | |
|---------------|-----------------------------------|--------------------|--|
| Notes: | (*) View from motor coupling side | | |
| OFFER No. | Pos. | Date 16/01/2020 | |