

Customer:		Ref.:	
Item	Quantity	Required flow	n.d.
Type	CENTRIFUGAL PUMP WITH HORIZONTAL SHAFT	Model	NC32-200

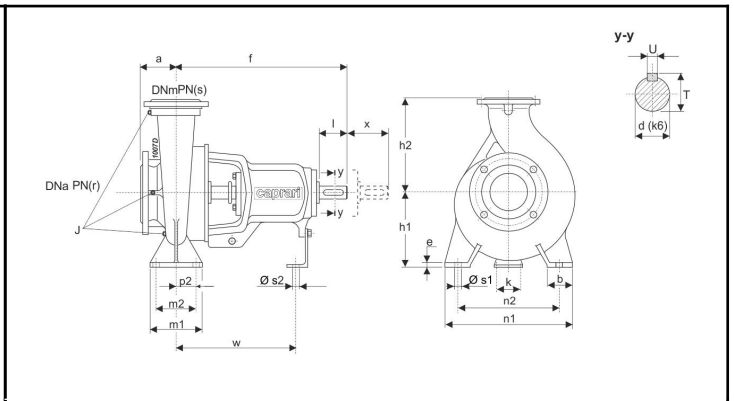
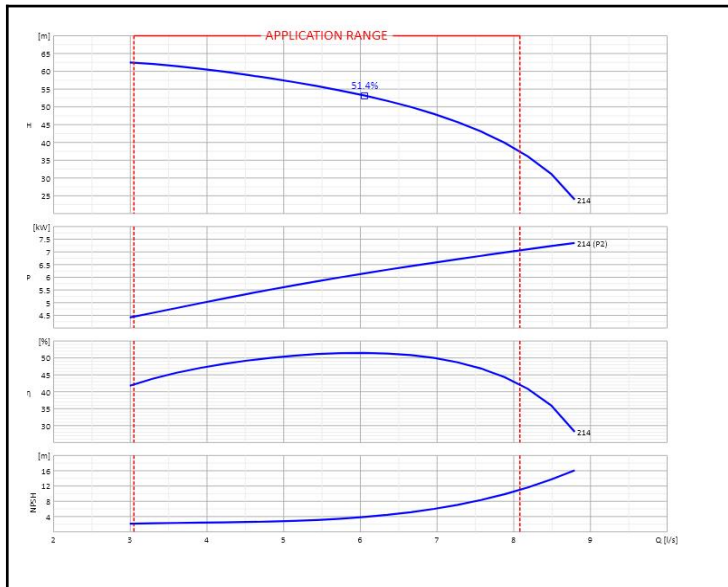

DNm	32	f	360	n2	190
DNa	50	k	110	p2	n.d.
J	G1/4, G3	l	50	s2	14
T	27	r	16	h1	160
U	8	s	16	m1	100
a	80	w	260	n1	240
b	50	x	100	s1	14
d	24	h2	180		
e	14	m2	70		

OPERATING DATA - UNI/ISO 9906:2012 grade 3B - M.E.I.≥0.40					CONSTRUCTION CHARACTERISTICS		
Q [l/s]	H [m]	P [kW]	η [%]	NPSH [m]	UNI delivery flange DN	32	PN 16
					UNI suction flange DN	50	PN 16
					Total weight	41	Kg
					No. Stages	1	
					Pump seal	Mechanical	
					Type of installation	Horizontal	

OPERATING LIMITS			OPERATING CHARACTERISTICS		
Pumped liquid	Water		Service flow rate	n.d.	n.d.
Max. temperature of pumped liquid	n.d.		Service head	n.d.	n.d.
Maximum density	1	kg/dm³	Qmin	3.05	8.08
Maximum viscosity	1	mm²/s	H (Q=0)	63.5	62.28
Max. solid content	50	g/m³	Hmax (Qmin)		
Max. no. starts/hr	n.d.		P2 Duty Point	n.d.	7.04
Maximum operating time with closed port	2min (3500 rpm) 6min (1450 rpm) [40 °C]		P2max		kW
			Pump hydraulic efficiency	n.d.	n.d.
			Rotation speed	2900	1/min
			Sense of rotation (*)	Clockwise	
			Number of pumps installed	Operating	Stand-by
				1	0

PUMP MATERIALS			
Pump casing	Cast iron	Stuffing box	n.d.
Impeller	Cast iron	Duck foot pedestal	Steel
Lantern bracket	Cast iron	Cover bearing	Cast iron
Shaft	Stainless steel		
Wear ring	Cast iron		
Support	Cast iron		
Bearing	n.d.		
Water retainer ring	Nitrile rubber		
Feather key	Stainless steel		
Feather key 2	Steel		
Seal ring	Nitrile rubber		
Mechanical seal	Silicon carbide/silicon carbide		
Packing	n.d.		
Spacer sleeve	Stainless steel		
Shaft sleeve	n.d.		
Seal ring	Nitrile rubber		
Cover mechanical seal	Cast iron		

Notes:	(*) View from motor coupling side		
OFFER No.	Pos.	Date	
		16/01/2020	