

Customer:		Ref.:	
Item	Quantity	Required flow	n.d.
Type	CENTRIFUGAL PUMP WITH HORIZONTAL SHAFT	Model	MEC-AG3/100A

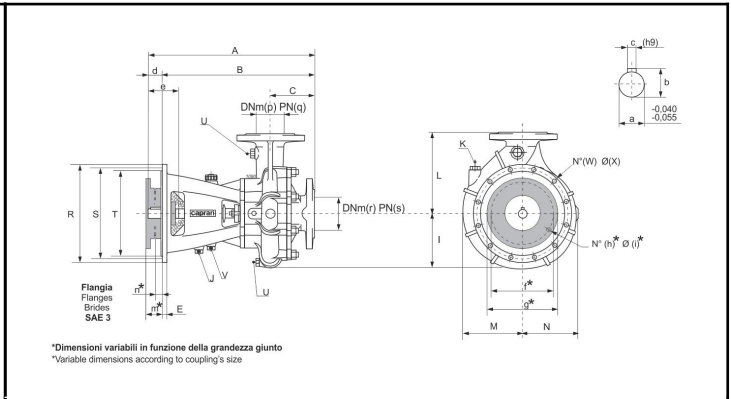
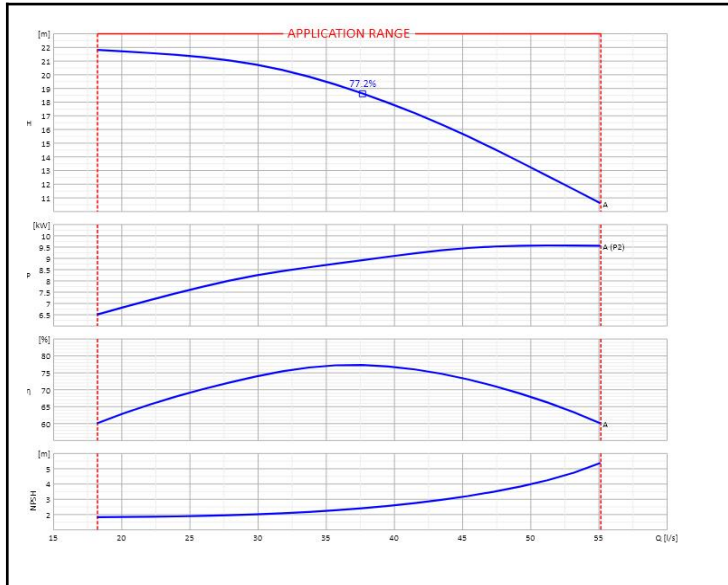

Dimensions [mm]

A	556	N	188	b	38
B	536	R	451	c	10
C	147	S	428.6	d	20
E	20	T	409.6	e	86
I	204	U	G 3/8"	p	100
J	G 3/8"	V	G 1/2"	q	16
K	G 3/8"	W	12	r	125
L	300	X	11.5	s	16
M	220	a	35		

OPERATING DATA- ISO 9906:2012 3B -					CONSTRUCTION CHARACTERISTICS			
Q [l/s]	H [m]	P [kW]	η [%]	NPSH [m]	UNI delivery flange DN	100	PN	16
					UNI suction flange DN	125	PN	16
					Total weight	120		Kg
					No. Stages		1	
					Pump seal		Packing	
					Type of installation		Horizontal	

OPERATING LIMITS			OPERATING CHARACTERISTICS			
Pumped liquid	Water		Service flow rate	n.d.		n.d.
Max. temperature of pumped liquid	n.d.		Service head	n.d.		n.d.
Maximum density	1	kg/dm ³	Qmin	18.22	55.14	l/s
Maximum viscosity	1	mm ² /s	H (Q=0)	21.35	21.79	m
Max. solid content	20	g/m ³	P2 Duty Point	n.d.	9.56	kW
Max. no. starts/hr	n.d.		P2max			
Maximum operating time with closed port	10min (2650rpm) [40°C]		Pump hydraulic efficiency	n.d.		n.d.
			Rotation speed	1450		1/min
			Sense of rotation (*)	Clockwise		
Number of pumps installed			Operating	1	Stand-by	0

PUMP MATERIALS	
Delivery casing	Cast iron
Suction casing	Cast iron
Impeller	Cast iron
Stuffing box	Cast iron
Wear ring	Cast iron
Deflector	Rubber
Packing	Ribbon cable in GORE
Mechanical seal	n.d.
Feather key	Steel
Lantern bracket	Cast iron
Pto shaft guard	Stainless steel
Pump shaft	Stainless steel
V seal ring	Rubber
Bearing	n.d.

Notes:	(*) View from motor coupling side
OFFER No.	Pos.
	Date 16/01/2020