

<b>Customer:</b>		<b>Ref.:</b>	
<b>Item</b>	Quantity	<b>Required flow</b>	n.d.
<b>Type</b>	CENTRIFUGAL PUMP WITH HORIZONTAL SHAFT	<b>Model</b>	MEC-MG100-1/2E

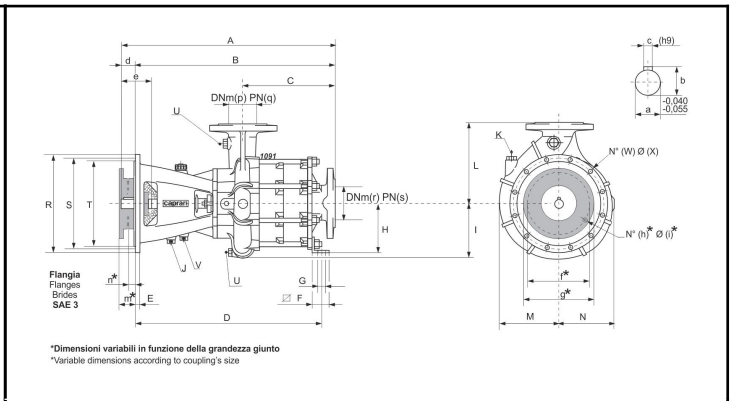
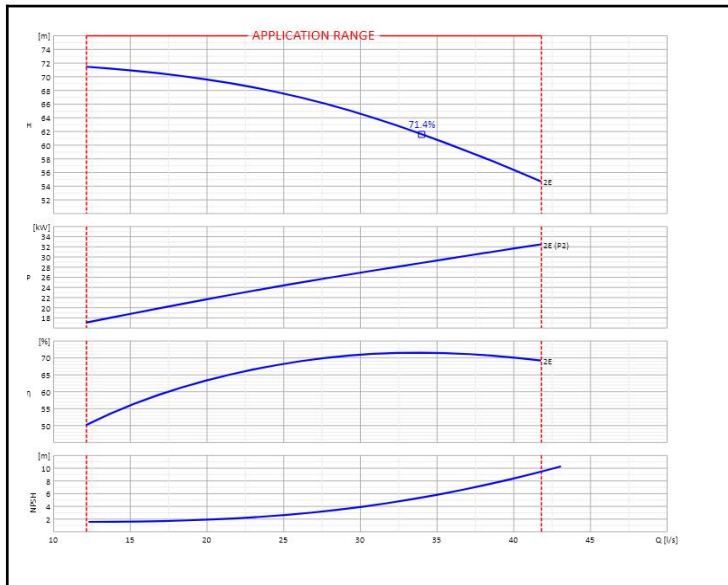

Dimensions [mm]

A	777	J	G 3/8"	V	G 1/2"	q	16
B	757	K	G 3/8"	W	12	r	100
C	286	L	400	X	11.5	s	16
D	n.d.	M	285	a	45		
E	20	N	263	b	48.5		
F	n.d.	R	451	c	14		
G	n.d.	S	428.6	d	20		
H	n.d.	T	409.6	e	102		
I	286	U	G 3/8"	p	100		

OPERATING DATA - ISO 9906:2012 3B -					CONSTRUCTION CHARACTERISTICS			
Q [l/s]	H [m]	P [kW]	η [%]	NPSH [m]	UNI delivery flange DN	100	PN	16
					UNI suction flange DN	125	PN	16
					Total weight	253		Kg
					No. Stages		2	
					Pump seal		Packing	
					Type of installation		Horizontal	

OPERATING LIMITS				OPERATING CHARACTERISTICS			
Pumped liquid	Water			Service flow rate	n.d.	n.d.	
Max. temperature of pumped liquid	n.d.			Service head	n.d.	n.d.	
Maximum density	1	kg/dm <sup>3</sup>		Qmin	12.14	41.8	l/s
Maximum viscosity	1	mm <sup>2</sup> /s		H (Q=0)	72.47	71.41	m
Max. solid content	20	g/m <sup>3</sup>		P2 Duty Point	n.d.	32.4	kW
Max. no. starts/hr	n.d.			P2max			
Maximum operating time with closed port	10min (2400rpm) [40 °C]	n.d.		Pump hydraulic efficiency	n.d.	n.d.	
				Rotation speed	1450	1/min	
				Sense of rotation (*)	n.d.		
Number of pumps installed				Operating	1	Stand-by	0

PUMP MATERIALS	
Delivery casing	Nodular cast iron
Suction casing	Cast iron
Impeller	Cast iron
Diffuser	Cast iron
Casing	Cast iron
Stuffing box	Cast iron
Wear ring	Cast iron
Bearing bush	
Packing	Graphited cord
Lantern bracket	Cast iron
Pump shaft	Stainless steel
Bearing flange	Cast iron
Shaft sleeve	Steel
Shaft guard	Stainless steel
Feather key	Steel
Tie rod	Steel

<b>Notes:</b>	(*) View from motor coupling side
OFFER No.	Pos.
	Date 16/01/2020