

<b>Customer:</b>		<b>Ref.:</b>	
<b>Item</b>	Quantity	<b>Required flow</b>	n.d.
<b>Type</b>	CENTRIFUGAL PUMP WITH HORIZONTAL SHAFT	<b>Model</b>	MEC-MG80/2I

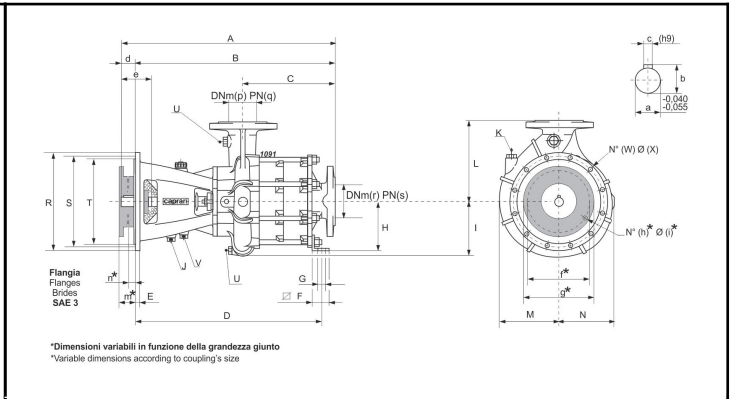
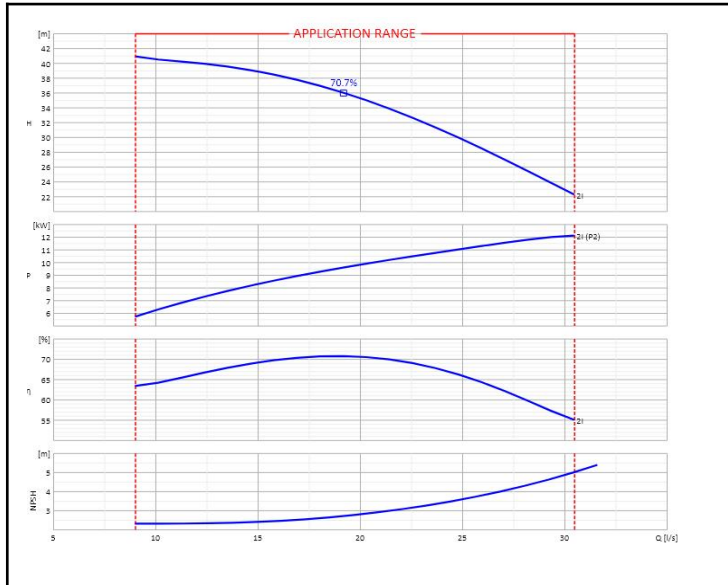

Dimensions [mm]

A	677	J	G 3/8"	V	G 1/2"	q	16
B	657	K	G 3/8"	W	12	r	100
C	250	L	325	X	11.5	s	16
D	n.d.	M	244	a	35		
E	20	N	222	b	38		
F	n.d.	R	451	c	10		
G	n.d.	S	428.6	d	20		
H	n.d.	T	409.6	e	86		
I	223	U	G 3/8"	p	80		

OPERATING DATA- ISO 9906:2012 3B -					CONSTRUCTION CHARACTERISTICS			
Q [l/s]	H [m]	P [kW]	η [%]	NPSH [m]	UNI delivery flange DN	80	PN	16
					UNI suction flange DN	100	PN	16
					Total weight	127		Kg
					No. Stages	2		
					Pump seal		Packing	
					Type of installation		Horizontal	

OPERATING LIMITS			OPERATING CHARACTERISTICS			
Pumped liquid	Water		Service flow rate		n.d.	n.d.
Max. temperature of pumped liquid	n.d.		Service head		n.d.	n.d.
Maximum density	1	kg/dm <sup>3</sup>	Qmin	Qmax	9	30.48
Maximum viscosity	1	mm <sup>2</sup> /s	H (Q=0) Hmax (Qmin)		39.91	40.9
Max. solid content	20	g/m <sup>3</sup>	P2 Duty Point	P2max	n.d.	12.09
Max. no. starts/hr	n.d.		Pump hydraulic efficiency		n.d.	n.d.
Maximum operating time with closed port	10min (2400rpm) [40 °C]		Rotation speed		1450	1/min
			Sense of rotation (*)		n.d.	
			Number of pumps installed		Operating	Stand-by
					1	0

PUMP MATERIALS	
Delivery casing	Cast iron
Suction casing	Cast iron
Impeller	Cast iron
Diffuser	Cast iron
Casing	Cast iron
Stuffing box	Cast iron
Wear ring	Cast iron
Bearing bush	
Packing	Ribbon cable in GORE
Lantern bracket	Cast iron
Pump shaft	Stainless steel
Bearing flange	Cast iron
Shaft sleeve	
Shaft guard	Stainless steel
Feather key	Steel
Tie rod	Steel

<b>Notes:</b>	(*) View from motor coupling side
OFFER No.	Pos.
	Date 16/01/2020