

Customer:		Ref.:	
Item	Quantity	Required flow	n.d.
Type	VERTICAL LINESHAFT PUMP	Model	P10F/6/24/1A

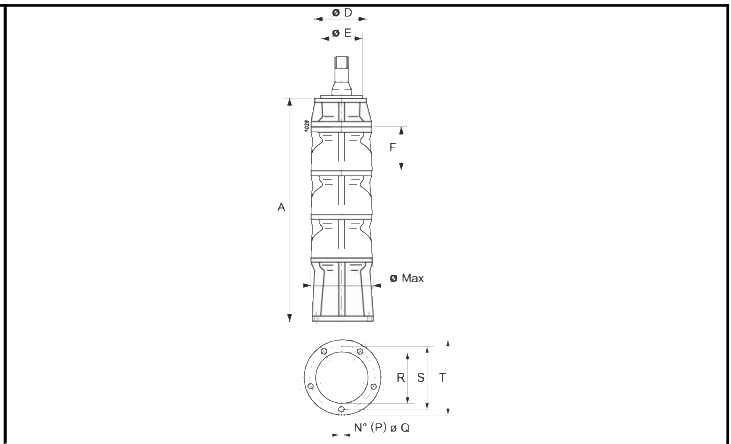
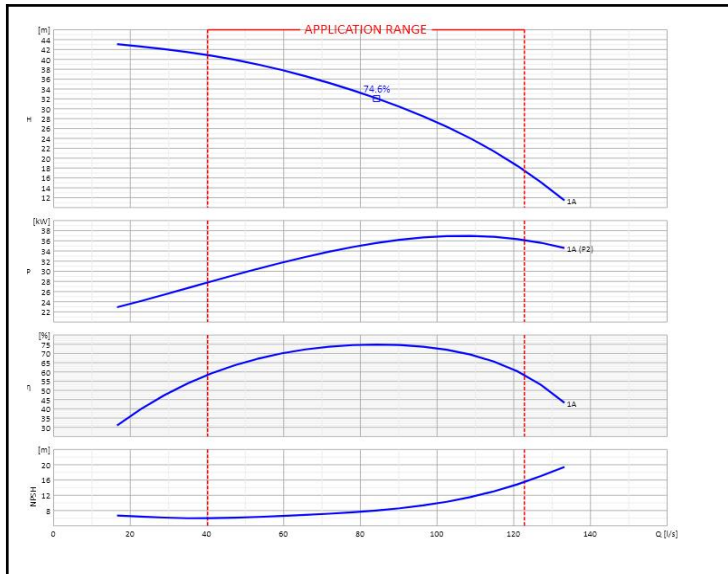

Dimensions [mm]

OPERATING DATA- ISO 9906:2012 3B -					CONSTRUCTION CHARACTERISTICS				
Q [l/s]	H [m]	P [kW]	η [%]	NPSH [m]	Delivery diameter	n.d.	n.d.	PN	n.a
					Ass'y weight	50		Kg	
					No. Stages	1			
					Seal	Packing			
					Total moment of inertia	9375 Kgm ²			
					Installation depth (m)	n.d.	mm		

OPERATING LIMITS				PUMP MATERIALS			
Pumped liquid	Water			Delivery body	Cast iron		
Max. temp. of pumped liquid	60	°C		Diffuser unit	Cast iron		
Maximum density	1	kg/dm ³		Suction casing	Cast iron		
Maximum viscosity	1	mm ² /s		Impeller	Cast iron		
Max. solid content	40	g/m ³		Shaft	Stainless steel		
Max. number of starts/hr	n.d.			Coupling	Stainless steel		
Minimum immersion depth	600	mm		Pump shaft bearing bush	Stainless steel/rubber		

OPERATING CHARACTERISTICS					LINESHAFT MATERIALS			
Service flow rate	n.d.		n.d.		Taper lock	Stainless steel		
Service head	n.d.		n.d.		Wear ring	Steel		
Qmin	Qmax	40.2	122.8	l/s	Sand guard	Stainless steel/rubber		
H (Q=0)	Hmax (Qmin)	45.2	40.79	m	****	****		
Pump efficiency	Overall efficiency	n.d.	n.d.	n.d.	****	****		
P2 absorbed	P2max	n.d.	36.89	kW	****	****		
Sense of rotation (*)	n.d.				****	****		
Number of pumps installed	Operating		Stand-by		****	****		
	1		0		****	****		

ELECTRIC MOTOR CHARACTERISTICS					DRIVE UNIT MATERIALS			
Nominal power	n.d.		n.d.		****	****		
Rated frequency	n.d.		n.d.		****	****		
Rated voltage	n.d.		n.d.		****	****		
Rated current	n.d.		n.d.		****	****		
No. Poles	Rotation speed	n.d.	2900	1/min	****	****		
Efficiency 4/4 - 3/4	- %				****	****		
Power factor 4/4 - 3/4	n.d.				****	****		
Is/In	Ts/Tn	n.d.	n.d.		****	****		
Protection class	n.d.				****	****		
Efficiency class					****	****		

Notes:	(*)		
OFFER No.	Pos.	Date 16/01/2020	